

ThermTec

VENTUS

Multi-Spectrum Binocular Ventus Series User Manual



Download on the
App Store



GET IT ON
Google Play



V1.0

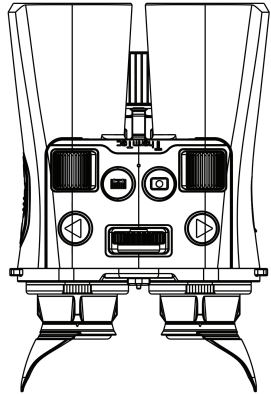
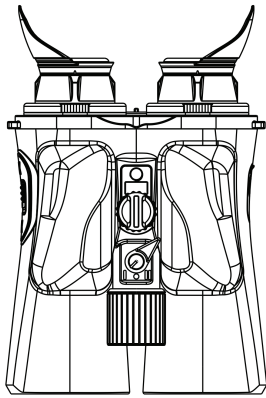

CE

UK
CA

RoHS



Contents

Legal Information	4
About this Manual	4
Trademarks	4
Disclaimer	4
1. Overview	6
2. Features	7
3. Specifications	8
4. Packing List	9
5. Appearance	10
5.1 Product Size & Drawing	10
5.2 Button Controls Description	11
5.3 Buttons and Controls	12
6. Quick Start Guide	13
7. Main Menu	20
8. Digital Magnetic Compass Calibration	38
9. Download "ThermTec Outdoor" APP	39
10. Firmware Upgrade	39
11. Technical Inspection	40
12. Maintenance	41
Using Environment	41
Emergency	42
Safety Information	42
Regulatory Information	45

Legal Information

COPYRIGHT © 2026 ThermTec Technology Co., Ltd. ALL RIGHTS RESERVED.

About this Manual

The Manual includes instructions for using and managing the product, pictures, charts, images and all other information hereinafter are for explanation and description only. The information contained in the Manual is subject to change, without notice due to firmware updates or other reasons. Please find the latest version of this Manual at the ThermTec website (<https://www.thermeyerotec.com>).

Please use this Manual with the guidance and assistance of professionals trained in supporting the product.

Trademarks

ThermTec and other ThermTec's trademarks and logos are the properties of ThermTec in various jurisdictions. Other trademarks and logos mentioned are the properties of their respective owners.

Disclaimer

To the maximum extent permitted by applicable law, this Manual and the product described, with its hardware, software and firmware, are provided "As is" and "With all faults and errors". ThermTec makes no warranties, express or implied, including without limitation, merchant ability, satisfactory quality, or fitness for a particular purpose. The use of the product by you is at your own risk. In no event will ThermTec be liable to you for any special, consequential, incidental, or indirect damages, including, among others, damages for loss of business profits, business interruption, or loss of data, corruption of systems, or loss of documentation, whether based on breach of contract, tort (including negligence), product liability, or otherwise, in connection with the use of the product, even if ThermTec has been advised of the possibility of such damages or loss.

You acknowledge that the nature of the internet provides for inherent security risks, and ThermTec shall not take any responsibilities for abnormal operation, privacy leakage or other damages resulting from cyber-attack, hacker attack, virus infection, or other internet security risks; however, ThermTec will provide timely technical support if required.

You agree to use this product in compliance with all applicable laws, and you are solely responsible for ensuring that your use conforms to the applicable law. Especially, you are responsible, for using this product in a manner that does not infringe on the rights of third parties, including without limitation, rights of publicity, intellectual property rights, or data protection and other privacy rights. You shall not use this product for any prohibited end-uses, including the development or production of weapons of mass destruction, the development or production of chemical or biological weapons, any activities in the context related to any nuclear explosive or unsafe nuclear fuel-cycle, or in support of human rights abuses.

In the event of any conflicts between this manual and the applicable law, the latter prevails.

1 Overview

The Ventus is a high-performance binocular imaging system designed for both visible-light and thermal imaging applications. It features a fully integrated vision system combining a 15 mK ultra-high-sensitivity infrared detector with advanced 4K Ultra visible imaging, enabling exceptional target identification even in harsh weather conditions or environments with minimal thermal contrast. Equipped with precise laser rangefinding and switchable dual-band 850 nm / 940 nm infrared illumination, the Ventus ensures a clear and reliable field of view across day and night operations. With its exceptional versatility and intuitive ergonomics, the Ventus series redefines outdoor observation and situational awareness.



2

Features

- 640×512@12μm thermal imaging sensor
- NETD < 15mK
- 4K Ultra CMOS sensor
- Integrated 1000m laser rangefinder
- 1600×1200, 0.5 inch AMOLED display
- Two replaceable 18650 batteries
- 850nm/940nm dual-band IR illuminator switch
- Picture in Picture
- Built-in 64 GB storage
- EIS vision stability
- TSR algorithm
- Proximity sensor
- Adjustable interpupillary distance: 60-72mm
- Ergonomically designed hand grip

3 Specifications

Ventus

Model	Ventus 635L	Ventus 650L
Thermal Module		
Resolution	640×512	
Pixel pitch	12μm	
NETD	15mK@300K	
Spectral range	8-14μm	
Objective lens	35mm/F0.9	50mm/F1.0
Field of View/m@100m	12.5°×10°/21.9×17.6	8.8°×7.0°/15.4×12.3
Frame rate	50Hz	
Magnification	2.6X-10.4X(4X)	3.7X-14.8X(4X)
Detection range	1800m	2600m
Optical Module		
Resolution	3536×3536, 2μm	
Field of view/m@100m	8.1°×8.1°/14.14×14.14	
Objective lens	50mm/F1.4	
IR illuminator wavelength	850nm/940nm switchable	
Viewing range at night	850nm: 400m / 940nm: 350m	
Magnification	4X-16X(4X)	
Image Display		
Type	AMOLED	
Resolution	1600×1200	
Display size	0.5 inch	
Color palette	6	
Eye relief	20mm	
Exit pupil	8mm	
Diopter	±5D	

Interpupillary adjustment range	60 mm to 72 mm	
Image mode	Forest/Rainy	
TSR algorithm	Yes	
Laser Rangefinder		
Safety class	Class 1	
Wavelength	905nm	
Range	1000m	
Accuracy	±1m	
Function		
Photo/Video playback	Yes	
Audio recording	Yes	
Azimuth	Yes	
Digital magnetic compass	Yes	
Hotspot	Yes	
Language	Multiple-language	
Storage	64GB EMMC	
PIP	Yes	
Heat track	Yes	
Local album	Yes	
OSD recording	Yes	
Burn prevention	Yes	
EIS	Yes	
Power Supply		
Battery type	Replaceable Li-ion battery (18650×2)	
Type-C power supply	5V DC, 2A/Data transfer	
Battery life	6h	
Environment		
Working temperature	-20- +50°C	
Protection level	IP67	
Weight, g	825±5	833±5
Size, mm	164(L)×127.6(W)×73(H)	
Mounting adapter	1/4-20-UNC	

4 Packing List



Binocular (x1)



Lens cloth (x1)



Service and support card (x1)

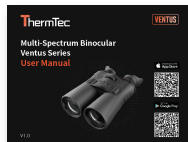

User manual (x1)



Bag (x1)



Charger (x1)



Lithium battery (x4)



USB cable (x1)



Screw driver (x1)



Tripod connector (x1)



Lens cover (x2)

5 Appearance



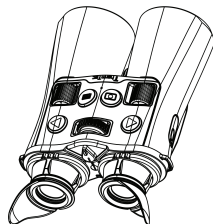
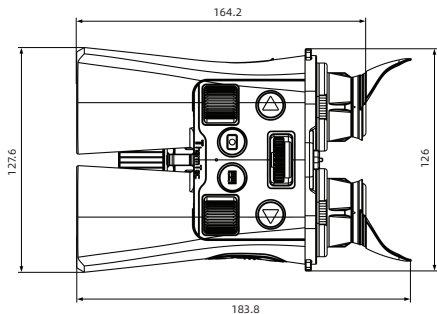
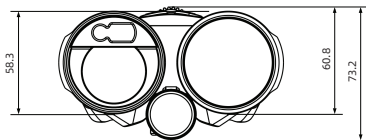
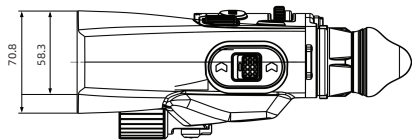



5.1 Product Size & Drawing



5

Appearance

5.2 Button Controls Description

Icon	Annotation	○	S	●
	Power Switch	Power off	Standby	Power on
Icon	Annotation	Single Press	Long Press	Double Click
	Measure Button	Continuous measuring	/	PIP
	Capture Button	Snapshot	Record	/
Icon	Annotation	Thermal Vision	Night Vision	
	Right Button Single Press	Image calibration	IR brightness	
	Left Button Single Press	Color palette switching	Day & night mode switch	
Before entering the main menu				
Icon	Annotation	Left-Right	Short Press Push	Hold Forward
	Rotary Encoder	Digital zoom	Thermal & night vision switch	Entering main menu
After entering the main menu				
Icon	Annotation	Bidirectional Rotation	Short Press Push	Hold Forward
	Rotary Encoder	Switch between menu items	Confirm / submenu	Exit

5 Appearance

5.3 Buttons and Controls



NO.	Comments
1	Eyecup
2	Eyeiece
3	Diopter adjustment ring
4	Left button
5	Power toggle switch
6	Rotary encoder
7	Focusing wheel for thermal sight
8	Ranging button
9	Capture button
10	Lens cap
11	Right button
12	USB port
13	Focusing wheel for visible light
14	Proximity sensor
15	IR illuminator toggle switch
16	Removable IR illumination
17	Battery compartment

6

Quick Start Guide

6.1 Battery Installation

The battery compartment is located on the left side of the device. Gently slide the latch and the battery cover will pop open. The device uses two 18650 batteries. The batteries are inserted in opposite polarities (one positive up and one reversed). After inserting the batteries, simply press the cover to close it.



6.2 Power On/Off & Standby Mode

Power on

The orange toggle switch is located in the middle of the device and has three position indicators.

- When the switch is moved to the “●” position, the device is powered on.
- S means standby (screen off)
- When the switch is moved to the “○” position, the device is powered off.



When the switch is moved to the S position, the device enters standby mode and the screen turns off. To wake up the device again, move the switch back to the “●” position.

6.3 Auto Screen Off

Below the toggle switch, there is a proximity sensor used to detect whether an object is approaching, thereby controlling the OLED on/off state. When the user's head comes within 3 cm of the proximity sensor, the OLED automatically turns on. Once the user moves away from the sensor, the OLED automatically turns off. This feature which is named with Proximity Sensor needs to be enabled in the settings; details will be explained in the Settings part.

6.4 Image Adjustment on Device

After turning on the device, first adjust the diopter (①) to ensure the OLED UI icons are clearly visible. Next, adjust the interpupillary distance (②) by sliding the eyepieces left or right until comfortable binocular viewing is achieved.

When using the thermal imaging mode, adjust the focus using the left focusing knob (③) to obtain a clear image.

When using the visible light imaging mode, adjust the focus using the right focusing knob (④) to obtain a clear image.

A single forward push of the rotary encoder (⑤) switches between infrared thermal imaging mode and visible light mode.

Two rotary control icons are displayed on the software user interface, one on the left and one on the right.

Depending on whether the system is operating in infrared thermal imaging mode or visible-light imaging mode, the corresponding rotary control indicator is automatically highlighted to show the active control. 



6.5 Thermal and Visible Light Mode Switching

After powering on the device, briefly push the rotary encoder forward once to switch between thermal mode and visible light mode. Push the encoder forward again to switch back.



6.6 Photo Capture & Video Recording

Press the Photo button once to capture a photo. Press and hold the Photo button to start video recording. All captured photos and recorded videos are saved in the device storage.
Note: This function is available in both thermal and visible light modes.



6.7 LRF Function

Press the Rangefinder button once to activate continuous laser ranging. A ranging cursor will be displayed on the screen. Align the cursor with the target by moving the device to measure the distance.

Note: This function is available in both thermal and visible light modes.



6.8 PIP

Double-click the ranging button to enable the PIP (Picture-in-Picture) function. Note: The PIP function for thermal imaging and visible imaging modes is configured separately. It must be enabled in the main menu, PIP display modes details will be explained in the Settings part.

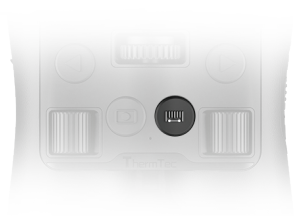

6.9 Thermal Image Quick Settings

6.9.1 Color Palette Switching

In thermal imaging mode, press the Left button once to switch the color palette.

Six color palette modes are available:



Color Palettes



White



Black



Red



Green



Golden



Violet

6.9.2 Image Calibration

In thermal imaging sight, single-click the right button to calibrate the image.



6.10 Visible Light Image Quick Settings

6.10.1 Day Light Mode & Night Vision Mode Switching

In visible light mode, press the Left button once to switch the image mode between Daylight Mode and Night Vision Mode.



6.10.2 IR Illuminator Adjustment

In Night Vision Mode

If the illuminator is required, move the illuminator switch to position I or II to turn it on.

- I: 850 nm
- O: Off
- II: 940 nm

Then, press the Right button once to adjust the illuminator brightness.

A total of five brightness levels are available:

- 0 (off)
- 1 ||
- 2 |||
- 3 ||||
- 4 |||||



Please note: when the brightness level is set to 0, the fill light is turned off. In this state, switching to 850 nm or 940 nm cannot be observed on the device. If there is no response when switching wavelengths, please press the right button to adjust the fill light brightness level.

In addition, the adjustment knob on the illuminator is used to control the beam focus and spread. Adjust it according to the actual operating conditions.



Note: If the illuminator is not required, it can be removed by loosening the fixing screw and detaching the illuminator from the device.



6.11 Power Supply

The battery can be removed and only charged separately using a charger.





7 Main Menu

All settings and controls in the main menu interface are operated using the thermal encoder.

The following is a brief introduction to the operation methods:

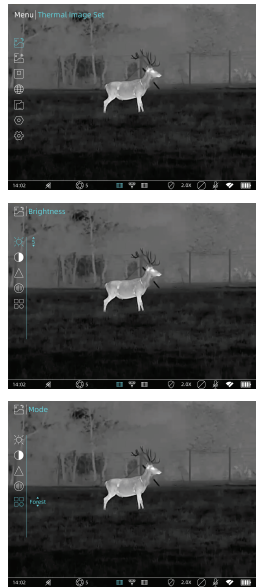
- On the main interface, press and hold the rotary encoder forward for 2 seconds to enter the main menu.
- Rotate the encoder left or right to move the cursor and select the desired icon.
- Briefly push the encoder forward once to confirm or enter the next-level menu.
- When a parameter is selected for adjustment, rotate the encoder left or right to change the value, then push the encoder forward once to confirm and save the setting.
- Press and hold the encoder forward for 2 seconds to return to the previous menu or exit.

 <p>Thermal Image Set</p>		<p>Thermal image settings after entering thermal image settings , four adjustable parameters are available:</p> <ul style="list-style-type: none">● ✖ Brightness: 1~10● ● Contrast: 1~10● Δ Sharpness: 0~10● @ Denoise: 0~10 <p>And two image modes  are available and can be switched according to actual usage conditions:</p> <ul style="list-style-type: none">● Forest● Rainy
--	---	--



Day Image Set

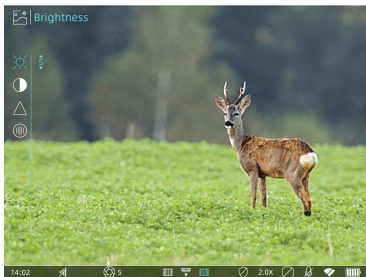
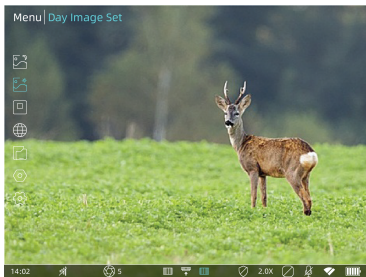

Day Image Set

After entering Day Image Set 

Four adjustable parameters
are available:

- ☼ Brightness: 1~10
- 🌑 Contrast: 1~10
- ▲ Sharpness: 0~10
- 🌀 Denoise: 0~10



PIP



PIP

The PIP function  must be enabled in the menu before it can be activated using the buttons. After entering the settings interface:

- Turn ON the switch 
- Select the display mode: Daytime or Thermal

1: When the device is in single-spectrum PIP mode (CMOS + CMOS PIP / Thermal + Thermal PIP), the default PIP window is displayed at 4× magnification, and digital zoom applies only to the main image.

2: When the device is in multi-spectrum PIP mode (Thermal + CMOS PIP / CMOS + Thermal PIP), the PIP window displays the other channel at 1× by default, and digital zoom applies only to the main image.



WLAN



WLAN

After enabling WLAN function , the device Wi-Fi network can be found and connected to using a mobile phone.

- Name: Ventus+Module+Serial number
- Password: 12345678

The Wi-Fi network name and password are set to default and cannot be modified.



Files

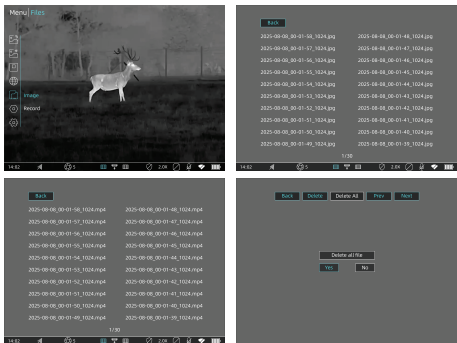

File Storage

After entering the File option , two separate folders are available:

- Image
- Record

These folders store the photos and videos captured by the device, respectively.

After entering a folder, a list of stored files will be displayed. Selecting an image or video allows user to perform operations such as viewing or deleting the file.



Setting

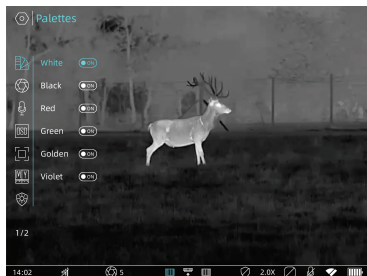

Setting-Palettes

In the Palettes settings , six color options are available for selection. Users can switch between them according to actual operating conditions.

- White
- Black
- Red
- Green
- Golden
- Violet

Note: This function is only available in thermal imaging mode.



Setting



Setting-Correction

Image Calibration  can be set to the following modes:

- Automatic
- Manual

In Automatic mode, a 10-second countdown prompt will be displayed before calibration is performed.



Setting-Audio

After enabling the Audio function , audio will be recorded together with video during recording.



Setting-OSD

After the OSD function  is turned off, no icons will be displayed on the main interface, allowing users to enjoy a more immersive viewing experience.

Users can configure this setting according to their personal preferences.



Setting



Setting-Tracking

When the Tracking function  is enabled, a cursor will appear on the screen. When a heat source target enters the field of view, the cursor will follow the heat source for tracking.



Setting-Unit

In the Unit settings , users can switch between metric and imperial units according to their personal preference.



Setting

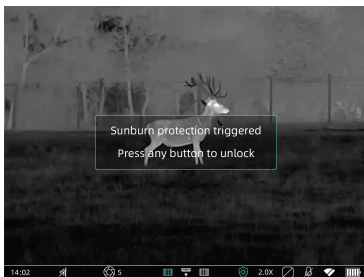

Setting-Anti-Burn

The anti-burn protection function  is enabled by default to protect the device and prevent detector damage if it is accidentally aimed at the sun. When the protection is triggered, press any button to unlock the device screen.



Setting



Setting-Orient

When Orient  is enabled, the main interface will display three angles:

- Azimuth (center of the screen)
- Roll (left side of the screen)
- Pitch (right side of the screen)

When using the device for the first time, gyroscope calibration  is required. The calibration procedure will be explained in Chapter 8.



Setting

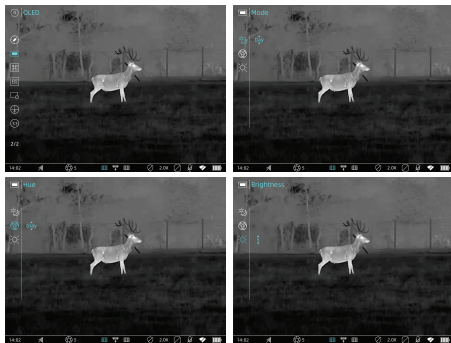

Setting-OLED

OLED-Mode:

After entering the OLED settings,  you can switch between modes:

- Day
- Night

OLED-Hue:

Background color adjustment:

Hue  Users can change the OLED background color based on personal preference:

- Grey
- Blue
- Purple
- Red

OLED-Brightness:

User can adjust the display brightness  of the OLED, the range is :

- 1-10



Setting

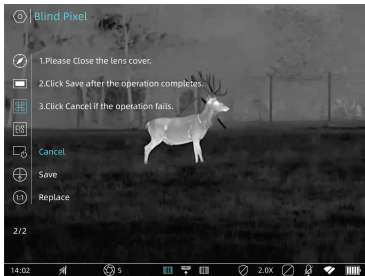

Blind Pixel

Note: Applicable only to infrared thermal imaging.

Please follow the Blind Pixel  steps below to perform bad pixel replacement:

1. Put the lens cap on first.
2. Tap **Cancel** to prevent accidental operation.
3. Tap **Replace** repeatedly until the dead pixels are removed.
4. Tap **Save**.



Setting-EIS

After the Electronic Image Stabilization function  is enabled, the image can be effectively stabilized during high-magnification observation, providing a smoother and more stable viewing experience. Visible light mode only.



Setting



Proximity Sensor

After this function is enabled, the device's automatic screen-off feature will also be activated. If the main power switch is set to the standby position, this function will not take effect.



FOV Sync

After this function is enabled, the fields of view of the dual channels will be automatically matched and adjusted in sync, ensuring image consistency when switching between channels. This effectively reduces the discomfort caused by channel switching and significantly improves overall viewing continuity and user experience.



Setting



Ballistic Calculator

After this function is enabled, you can input the corresponding parameters to calculate the bullet drop at a specified distance which measured by LRF, providing assistance for hunting and shooting.

The calculated distance and bullet drop will be displayed in the upper right corner of the screen, and the user can switch their units.



System



System-Logo

Users can enable or disable the display of the ThermTec logo .



System-Time & Date

Users can modify the date and time .



System



System-Language

Users can change the language according to their needs.



System-Version

Users can view detailed device information:

- SN
- Version
- ISPVer



System



System-Reset

After confirming Reset , all settings will be restored to factory defaults.



System



System-Update

Users can Update  the device using the firmware corresponding to their device model series provided on the ThermTec official website.

The details will be explained in Chapter 10.

8 Digital Magnetic Compass Calibration

Before using the Orient function for the first time, the Digital magnetid Compass must be calibrated.

- Enter the Orient function and tap Calibrate. The calibration steps will be displayed on the screen.
- Tap Start, then follow the on-screen guidance symbols to move and rotate the device.
- The process takes 10 seconds.



After calibration is completed, enable the function to display:

- Azimuth (center of the screen)
- Roll (left side of the screen)
- Pitch (right side of the screen)



9 Download “ThermTec Outdoor” APP

You may download the “ThermTec Outdoor” APP through the QR code.



10 Firmware Upgrade

The Ventus Series supports the ThermTec Outdoor APP, which allows real-time transmission of images and videos from the device to a smartphone or tablet via the device hotspot.

The electronic version of this User Manual and the latest firmware can be downloaded from the ThermTec website: www.thermeyeretec.com

Firmware upgrades can also be performed via the ThermTec Outdoor APP.

Upgrading via APP

- Open the ThermTec Outdoor APP.
- After the device is connected, the APP will indicate if a firmware update is available.
- Before downloading the firmware, please turn on mobile data.
- After the firmware is downloaded and ready for upgrade, please turn off mobile data to ensure a stable upgrade process.
- Once the upgrade is completed, the device will automatically reboot.

Upgrading via PC

- Download the corresponding firmware upgrade package from the official website: www.thermeyeretec.com.
- Connect the device to the PC using a Type-C cable.
- Copy the corresponding firmware update file to the device's internal storage folder named “Storage”.

- Push forward the rotary encoder 2s entering the main menu, then rotate the encoder and press to select the Update icon under System option, and the device will display an "Update" prompt.
- After completion, enter the Version menu to verify the firmware version.
- A detailed firmware upgrade instruction video is available on the official ThermTec channels.



11 Technical Inspection

A technical inspection of the device is recommended before use.

- Check the external appearance of the device. Ensure that there are no cracks in the housing.
- Check the condition of the lens and eyepiece. Ensure there are no cracks, oily marks, dust, or other contaminants.
- Check the image display. Ensure there are no dead pixels or abnormal lines on the screen. If any issues are found, please contact your dealer or point of purchase for replacement.

Attention: Damage to the sensor caused by improper use or human factors is not covered by the warranty.

12 Maintenance

Maintenance should be performed at least twice a year and includes the following procedures:

- If the product does not work properly, please contact your dealer or the nearest service center. We shall not assume any responsibility for problems caused by unauthorized repair or maintenance.
- Make sure that the power has been disconnected before device teardown and repair by professionals.
- Check the optical surfaces of objective lens, eyepiece, rangefinder, etc. If necessary, remove dust and sand from the optics using tools and solvent designed especially for this purpose (it is preferable to use a non-contact method).
- If the equipment is used in a manner not specified by the manufacturer, the protection provided by the device may be impaired.
- Wipe the exterior surfaces of metal, plastic, and silicone parts with a clean and soft cloth. Do not use chemically active substances, solvents, etc. as these may damage the paint.

Using Environment

- Make sure the running environment meets the requirement of the device. The operating temperature shall be $-20\text{ }^{\circ}\text{C}$ to $50\text{ }^{\circ}\text{C}$, and the operating humidity shall be from 5% to 95%.
- DO NOT expose the device to high electromagnetic radiation or dusty environments.
- DO NOT aim the lens at the sun or any other bright light.
- Place the device in a dry and well-ventilated environment.
- When any laser equipment is in use, make sure that the device lens is not exposed to the laser beam, or it may burn out.
- Avoid equipment installation on vibratory surface or places subject to shock (neglect may cause equipment damage).
- This equipment is not suitable for use in locations where children are likely to be present.
- This equipment is not suitable for use in locations where children are likely to be present.

Emergency

If smoke, odor, or noise arises from the device, immediately turn off the power, unplug the power cable, and contact the service center.

Laser

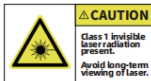

When any laser equipment is in use, make sure that the device lens is not exposed to the laser beam, or it may burn out. The laser radiation emitted from the device can cause eye injuries, burning of skin or inflammable substances. Before enabling the laser ranging function, make sure no human or inflammable substances are in front of the laser lens. Do not place the device where minors can fetch it. According to IEC 60825-1:2014, EN 60825-1:2014+A11:2021, and EN 50689:2021, this laser product is classified as Class 1 laser product and consumer laser product.

Safety Information

These instructions are intended to ensure that user can use the product correctly to avoid danger or property loss. Please read all the safety information carefully before using.

Transportation

- Keep the device in original or similar packaging while transporting it.
- Keep all wrappers after unpacking them for future use. In case of any failure occurred, you need to return the device to the factory with the original wrapper. Transportation without the original wrapper may result in damage on the device and the company shall not take any responsibilities.
- Do not drop the product or subject it to physical shock. Keep the device away from magnetic interference.

Power Supply

- If a power adapter is provided in the device package, use the provided adapter only. If no power adapter is provided, ensure the power adapter or other power supply complies with Limited Power Source. Refer to the product label for the power supply output parameters.

- Make sure the plug is properly connected to the power socket.
- DO NOT connect multiple devices to one power adapter, to avoid over heating or fire hazards caused by overload.
- The power delivered by the charger must be between min. 10 Watts required by the radio equipment, and max. 10.4 Watts in order to achieve the maximum charging speed.
- Use the battery provided by qualified manufacturer. Refer to the product specification for detailed battery requirements.
- Dispose of used batteries according to the instructions.
- CAUTION: Risks of short circuit, fire, or explosion if the battery is damaged. Frequent use, dropping, impact, corrosion, or compression of the battery may cause damages including cracked casing, detached plates, or leakage of internal liquid or gas, etc.

Battery

- The device supports removable li-ion battery. The battery rated voltage and capacity is 3.6 V/3300 mAh.
- CAUTION: Risk of explosion if the battery is replaced by an incorrect type. Replace with the same or equivalent type only.
- Batteries of improper size cannot be installed, and may cause abnormal shutdown.
- Improper replacement of the battery with an incorrect type may defeat a safeguard (for example, in the case of some lithium battery types).
- Please purchase the batteries recommended by the manufacturer if necessary.
- The purchased batteries by users need to comply with the relevant international standards about battery safety (e.g. EN/IEC standards).
- If the battery is damaged, stop using it immediately and dispose of it according to the instructions.
- Remove the battery if you do not use the device for a long time.
- For long-term storage of the battery, make sure it is fully charged every 2 months to ensure the battery quality. Otherwise, damage may occur.
- The built-in battery cannot be dismantled. Please contact the manufacture for repair if necessary.
- Make sure the battery temperature is between 0°C to 50°C (32°F to 122°F) when charging.
- Do not dispose of the battery into fire or a hot oven, or mechanically crush or cut the battery, which may result in an explosion.

- Do not leave the battery in an extremely high temperature or low air pressure environment, which may result in an explosion or the leakage of flammable liquid or gas.
- Confirm there is no flammable material within 2 m of the charger during charging.
- DO NOT place the device with battery or the battery alone near heating or fire source. Avoid direct sunlight.
- DO NOT place the battery in the reach of children.
- DO NOT swallow the battery to avoid chemical burns.
- This product contains a coin/button cell battery. If the coin/button cell battery is swallowed, it can cause severe internal burns in just 2 hours and can lead to death.
- If the battery compartment does not close securely, stop using the product and keep it away from children.
- If you think batteries might have been swallowed or placed inside any part of the body, seek immediate medical attention.

REGULATORY INFORMATION

This product and - if applicable - the supplied accessories too are marked with "CE" and comply therefore with the applicable harmonized European standards listed under the Directive 2014/53/EU (RED), Directive 2014/30/EU (EMC), Directive 2014/35/EU (LVD), Directive 2011/65/EU (RoHS).

The full text of the EU declaration of conformity is available at the following internet address:

<https://www.thermeyer-tec.com/declaration-of-conformity/>



Frequency Bands and Power (for CE). The frequency bands and transmitting power (radiated and/or conducted) nominal limits applicable to the following radio equipment are as follows: Wi-Fi 5GHz, 14 dBm

For the device without a supplied power adapter, use the power adapter provided by a qualified manufacturer. Refer to the product specification for detailed power requirements. For the device without a supplied battery, use the battery provided by a qualified manufacturer. Refer to the product specification for detailed battery requirements.

This product contains a battery and it is in conformity with the Regulation (EU) 2023/1542. The battery cannot be disposed of as unsorted municipal waste in the European Union. See the product documentation for specific battery information.



The battery is marked with this symbol, which may include lettering to indicate cadmium (Cd), or lead (Pb). For proper recycling, return the battery to your supplier or to a designated collection point. For more information see: www.recyclethis.info.



This product and - if applicable - the supplied accessories too are marked with “UKCA” and comply therefore with the following directives: Radio Equipment Regulations 2017, Electromagnetic Compatibility Regulations 2016, Electrical Equipment (Safety) Regulations 2016, the Restriction of the Use of Certain Hazardous Substances in Electrical and Electronic Equipment Regulations 2012.



This product and - if applicable - the supplied accessories too are marked with “RoHS” and comply therefore the requirements of Directive 2011/65/EU on the restriction of the use of certain hazardous substances in electrical and electronic equipment (“RoHS recast” or “RoHS 2”).



2012/19/EU (WEEE directive): Products marked with this symbol cannot be disposed of as unsorted municipal waste in the European Union. For proper recycling, return this product to your local supplier upon the purchase of equivalent new equipment, or dispose of it at designated collection points. For more information see: www.recyclethis.info.



Directive 2006/66/EC and its amendment 2013/56/EU (Battery Directive): This product contains a battery that cannot be disposed of as unsorted municipal waste in the European Union. See the product documentation for specific battery information. The battery is marked with this symbol, which may include lettering to indicate cadmium (Cd), lead (Pb), or mercury (Hg). For proper recycling, return the battery to your supplier or to a designated collection point. For more information see: www.recyclethis.info.



ThermTec Technology Co., Ltd.

✉ info@thermeyetec.com

🌐 www.thermeyetec.com



COPYRIGHT © 2026 ThermTec Technology Co., Ltd. ALL RIGHTS RESERVED.